

NATIONAL INSTITUTE OF TECHNOLOGY

TIRUCHIRAPPALLI – 15

Department of Production Engineering

Web : www.nitt.edu

Phone : 0431 - 2503509



TENDER DOCUMENT

Tender Notification No.: NITT/F.No:004-005/PLAN/2016-17/PRO/1

Dated:22.08.2016

- Name of the component : **Furniture items**
- Quantity required : **As listed in Section 3**
- EMD Amount : **Rs. 8500/-**
- Cost of the Tender Document : **Rs. 150/-**
- Delivery : **8 weeks**
- Last Date of submission of Tender : **09.09.2016 up to 3.00 pm**
- Address for submission of Tender : The Director,
National Institute of Technology- Tiruchirappalli,
Tiruchirappalli – 620015, Tamilnadu, India
Kind ATTN to: Dr. M. Duraiselvam
Asso. Professor & Head, Dept. of Production Engg.
Phone: 9489066240
Email: durai@nitt.edu
- Date of opening of technical bid : **09.09.2016 at 3.30 pm**



**NATIONAL INSTITUTE OF TECHNOLOGY
TIRUCHIRAPPALLI – 15**

DEPARTMENT OF PRODUCTION ENGINEERING

Tender Notification No.: NITT/F.No:004-005/PLAN/2016-17/PRO/1

Dated: 22.08.2016

NOTICE INVITING TENDER

The National Institute of Technology, Tiruchirappalli (NITT) is an autonomous body under MHRD, GOI, imparting Technical Education and engaged in Research Activities. It is proposed to procure the following item for the Departmental academic/research activities.

Sealed bids under **two bid system** are invited for the following component subject to the following terms and conditions, from the reputed manufacturers or their authorized dealers so as to reach this office on or before scheduled date and time. The technical cover will be opened on the same day in the presence of bidders or their authorized agents who may choose to be present.

Name of the component : Furniture items

Quantity required : As listed in section 3

EMD : **Rs. 8500/-**

Cost of the Tender Document : **Rs. 150/-**

Time for completion of supply after : 4 Weeks
placing purchase order

Last Date of submission of Tender : **09.09.2016 up to 3.00 pm**

Address for submission of Tender : The Director,
National Institute of Technology- Tiruchirappalli,
Tiruchirappalli – 620015, Tamilnadu, India
Kind ATTN to: Dr. M. Duraiselvam
Associate Professor and Head, Dept. of Production Engg.
Phone: 9489066240
Email: durai@nitt.edu

Place, Date and time of opening of bid:

Date: **09.09.2016**

Time: **3.30 pm**

Venue: **Central Stores, NITT**

Note : The Institute shall not be responsible for any postal delay about non-receipt / non delivery of the bids or due to wrong addressee.

INSTRUCTIONS TO BIDDERS

BIDDER'S COPY

1. This document set contains the following:
 - a) Terms and conditions of the Tender
 - b) Details of the Firm offering this Quote
 - c) Technical Compliance Form
 - d) Quotation form (Price Bid)
 - e) NIT-T's check list copy
2. The bidder's copy is for your future records. Please fill in and return only NIT-T's copy.
3. Please send the tenders in a sealed envelope superscribed as "**QUOTATIONS AGAINST TENDER NOTIFICATION NO: NITT/F.No:004-005/PLAN/2016-17/PRO/1**" so as to reach "The Director, National Institute of Technology, Tiruchirappalli - 620 015, India" on or before **09.09.2016 at 3.00 pm. Along with the Technical Compliance form (along with cover-2) and Quotation Forms (along with cover-3).**
4. For any further clarifications, contact by E-Mail: durai@nitt.edu or by written request to "The Registrar, National Institute of Technology, Tiruchirappalli - 620 015, India"

Last Date for receipt of tender at NIT-T : 09.09.2016 at 3.00 pm

Opening Date for technical bid : 09.09.2016 at 3.30 pm

CHECKLIST TO BE FILLED IN BY BIDDER	
List of documents to be enclosed	Completed & Signed
1. Terms and Conditions form	YES / NO
2. Details of the Firm offering this Quote	YES / NO
3. NIT-T's Quotation form (Technical & Price Bid)	YES / NO
4. Other technical specifications & pamphlets	YES / NO

- Note:** 1. "Cover" should contain the following:
- a. Form of "**Acceptance of Terms and Conditions**".
 - b. Form of "**Firm details**"
 - c. Pamphlets, if any (in a separate sealed cover)
 - d. Quotation Form (Technical and Price Bid)

Please retain this page with you for your future reference.

SECTION : 1 – TWO BID TENDER**Cover 1: Tender Cost**

(should be superscribed as 'Tender cost cover' duly indicating the Tender reference No. and the due date of opening)

Tender Cost is to be submitted by way of Demand Draft/FDR drawn on any Nationalized bank in India in favor of "The Director, NIT, Trichy" payable at Trichy. The bids submitted without Tender Cost will be treated as non-responsive and will be rejected.

Cover 2: Technical Bid

(should be superscribed as 'Technical Bid' duly indicating the Tender reference No. and the due date of opening)

Should contain:

- a. Copy of license certificate for manufacture/supply of the item
- b. Income Tax PAN number & TIN number.
- c. Warranty period offered for the tendered item to be specified. If the warranty period is not conforming with the schedule of requirements given in section 3 of the Tender document, the bid is liable to be treated as non-responsive and will be rejected.

Cover 3: Price Bid

(should be superscribed as 'Price Bid' duly indicating the Tender reference No. and the due date of opening)

Should contain:

- a. Price bid as per the format in Section-4 of the tender document

Note:

- a. If the prices are revealed in cover 1 or in cover 2, the offer will be summarily rejected.
- b. Each Cover shall be sent in a double sealed cover. The inner covers (Cover 1, Cover 2 and Cover 3) should be sealed individually with the Sellers's distinctive seal and superscribed with the tender reference No. and due date of opening. All inner covers shall be placed in a common outer cover which shall also be sealed with seller's distinctive seal and superscribed with the tender reference No. and due date of opening.
- c. Mention "Kind Attention: Dr. M. Duraiselvam, Associate Professor and Head, Department of Production Engineering" and submit at the address given in the Notice Inviting Tender.
- d. Cover 1 & 2 will be opened on the scheduled date and time mentioned in the tender enquiry.
- e. Cover 3 of the technically and commercially suitable offers alone will be opened on a date which will be intimated to the qualified bidders through E-mail only.

SECTION : 2 – TERMS AND CONDITIONS FORM

**IMPORTANT: READ THE FOLLOWING TERMS AND CONDITIONS AND
SIGN THE ACCEPTANCE CLAUSE FOLLOWING IT**

1. The offers should be addressed to “The Director, Kind Attention: Dr. M. Duraiselvam, Associate Professor and Head, Department of Production Engineering, National Institute of Technology, Tiruchirappalli 620015, India” and should be sent in a sealed envelope superscribed **BID AGAINST TENDER NOTIFICATION No.: NITT/F.No:004-005/PLAN/2016-17/PRO/1**” so as to reach us **on or before 09.09.2016**
2. Each offer should be sent in a sealed cover with the tender documents. Tenders received through email or FAX will not be considered.
3. The tenders will be opened on **09.09.2016 at 3.30 pm** in the presence of the vendors present with authorization letter from the respective companies / firms. Suppliers intending to attend the tender opening should intimate us in advance.
4. Full technical specifications and pamphlets should be sent along with the tenders. **Offers without proper technical specifications will be rejected.**
5. The rate quoted should be on unit basis excluding Taxes. Taxes and other charges should be quoted separately, considering exemptions if any.
6. All offers should indicate unit price (excluding taxes and duties applicable), Taxes and other charges should be mentioned separately, if any. Additional charges for packing, forwarding, freight, insurance etc., if any, should be clearly mentioned.
7. The Institute is not authorized to issue C and D forms of Sales tax certificate.
8. 100% payment will be made only after receipt of items. **No advance payment will be made.**
9. No revision of the price bid will be allowed once the price bids are opened and/or after our firm orders are placed.
10. **Payment of sales tax / VAT (on ultimate products)** as applicable on the closing date of tender will be to the supplier’s / contractor’s account. Any statutory variation (both plus and minus) in the rate of sales tax/VAT after closing date of tender/revised price bid but before the expiry of the contractual delivery / completion period will be to the account of the office. The bidder(s) should indicate, in their bid, the amount with exact rate of the Sales tax/VAT on ultimate finished product, as applicable at tendering stage, separately in the bid. In case the above information subsequently proves wrong, incorrect or misleading (a) this Institute will have no liability to reimburse the excess in the difference in rates of the item under which the duty/tax assessed finally (b) this Institute will have the right to recover the difference in case the rate of duty / tax finally assessed is on the lower side. Any increase in sales tax / VAT during extended period of the contract / supply order will be to supplier’s / contractor’s account where such extension in delivery of the materials/completion of the project was on the request of supplier / contractor. However, any decrease in sales tax/ VAT during extended period of the contract / supply order, will be to the account of this Institute.
11. **This institute is exempted from payment of service tax as per Sl.no. 9 of Government notification No25/2012-ST dated 20th June, 2012. The tenderer should verify the excise duty exemption certificates of this institution and service tax rules before submission of the Bid. It will be assumed on the submission of bid that excise duty exemption will be provided and no other conditions after the issue of purchase order will be accepted. No service tax will be paid by this institute.**
12. The warranty period should be clearly mentioned.
13. Quote should come from authorized dealer or distributor or reseller for each of the product quoted. An authorization letter should accompany your quote for each product quoted; otherwise it may lead to rejection.
14. The delivery period and other terms should be clearly mentioned.
15. The vendors are informed that they should not call us over phone or contact us in person. All clarifications can be obtained through E-Mail/FAX/Post. Vendors shall not make attempts to

establish unsolicited and un-authorized contact with us after the opening of the offers and prior to the notification of the award. Any attempt by any vendor to bring to bear extraneous pressures on us shall be sufficient reason to disqualify the vendor.

16. We are not responsible for accidental opening of the covers that are not properly superscribed and sealed before the time scheduled for opening.
17. The tender should be made only on the FORM which is available in our website, otherwise it shall lead to rejection. The FORM should be duly filled up (preferably **TYPE WRITTEN IN CAPITAL LETTERS**) and should clearly mention the features offered by the bidder against each specification.
18. Authorized signatory should sign on all the pages. Bids without authorized signatures or seal of the firm will be rejected.
19. **Liquidated damages:** If the bidder/supplier, after accepting the Purchase Order, fails to deliver any or all of the Goods within the period specified in the Order, NIT-T shall, without prejudice to its other remedies under the Rules of Purchase, proceed to cancel the order or agree to accept a delayed delivery on the condition of payment of liquidated damages by the bidder / supplier a sum equivalent to 0.50% of the total cost as indicated in the Purchase Order (which will be deemed as agreed price) for each week or part thereof of delay until actual delivery or performance is completed and such penal charges shall be limited to a maximum of 5% of the total cost. Once the maximum is reached NIT-T may proceed on its own to consider the termination / cancellation of the order.
20. Failure to comply with all the terms and conditions mentioned herein would result in the tender being summarily rejected.
21. Vendors are informed that once the companies are shortlisted based on the technical specification, only then the price bids of the firms that meet NIT-T's Technical specification / requirements would be compared.
22. NIT-T reserves the right to modify or alter the specifications after short listing of tenderers.
23. NIT-T reserves the right to change the order quantity or split the orders among multiple vendors without assigning any reason(s) whatsoever.
24. NIT-T reserves the right to reject any or all the tenders without assigning any reasons whatsoever.
25. NIT-T reserves the right to purchase decreased number of quantity of the item to be purchased.
26. The agencies should submit their rate as per the format given in Section 4 of the Notice Inviting Tender in this cover. All the pages of the bid should be signed affixing the seal. All corrections and overwriting should be initialed.
27. The tender will be acceptable only from the manufacturers or its authorized supplier.
28. The bid shall be in the format of price schedule given in Section 4. The contract form as per format given in section 5 shall be submitted. Incomplete or conditional tender will be rejected.
29. Details of quantity and the specifications are mentioned in Section 3 appended to this Notice Inviting Tender.
30. The Contractor/Supplier shall have no claim to any payment of compensation or otherwise whatsoever, on account of any profit or advantage which he might have derived from the execution of the work/supply in full but he did not derive in consequence of the foreclosure of the whole or part of the works.
31. In case of dispute, the matter will be subject to Tiruchirappalli, Tamil Nadu Jurisdiction only.

Validity of bids: The rate quote should be valid for a minimum of 120 days. No claim for escalation of rate will be considered after opening the Tender.

Clarification of Tender Document: A prospective bidder requiring any clarification of the Tender document may communicate to the contact person given in this notice inviting tender.

Amendment of tender document: At any time prior to the last date of receipt of bids, Institute may for any reason, whether at its own initiative or in response to a clarification requested by prospective bidder, modify the Tender document by an amendment in the NIT-T website only.

The Institute may at its own discretion extend the last date for the receipt of bids.

The bids shall be written in English language and any information printed in other language shall be accompanied by an English translation, in which case for the purpose of interpretation of the bid, the English translation shall govern.

The Institute reserves the right of accepting any bid other than the lowest or even rejecting all the bids without assigning any reasons therefor. The decision of the Institute Purchase Committee is final in all matters of tender and purchase.

The bidder should give the following declaration while submitting the Tender.

ACCEPTANCE

We accept the above terms and conditions and shall comply with them strictly.

NAME OF THE VENDOR:

ADDRESS :

Signature and seal

“DETAILS OF THE FIRM OFFERING THIS QUOTE”
(Write or print or type in block letters)

1. Name of the firm: _____ Date of incorporation: _____
2. Nature of the company (tick one): Government / Public / Private Company / Partnership / Proprietorship
3. Specify the number of years in this line of activity by the Company: ::
4. Provide the postal address, telephone & fax numbers, and email address of the nearest service center.
5. Number of service engineers in the above location trained on the product quoted along with their educational qualification, certification and designation (applicable only for instruments):
6. Assured response time for service calls in hours:

7. Delivery period from the date an official purchase order placed (in weeks):
8. Are you the authorized dealer or distributor or reseller for the products quoted?
9. Have you supplied “Furniture items” to National Institute of Technology, Tiruchirappalli in the last 3 years? If yes, specify the quantity supplied in the last 3 years and last PO reference:
10. On Manufacturer’s Side to whom NITT have to contact in case of delayed in supply and other issues committed by the authorized dealer / distributor / reseller :

Contact Person Name :
Address :
E-mail ID :
Telephone / Cell Phone :

DECLARATION

I/we have not tampered/modified the tender forms in any manner. In case, if the same is found to be tampered/modified, I/we understand that my/our tender will be summarily rejected and I/we am/are liable to be banned from doing business with NIT, Trichy and /or prosecuted.

Signature of the Bidder :

Name and Designation :

Business Address :

.....

.....

Place :

Date :

Seal of the Bidder's Firm

SECTION : 3 – SCHEDULE OF REQUIREMENTS, SPECIFICATIONS AND ALLIED DETAILS

Specification for furniture items

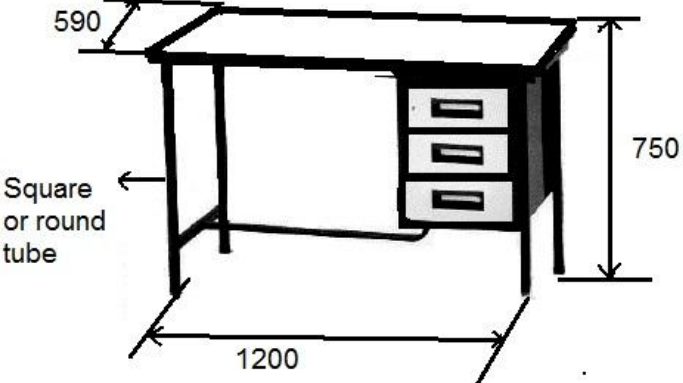
(1) Name of the item	:	Wooden working table with storage: (36 Nos)
<p>Specifications :</p> <ul style="list-style-type: none"> • Overall size (W x D x H) (minimum) : 1200 mm x 590 mm x 750 mm • Coated mild steel tube of diameter not less than 25mm and 14BG thickness. • Table top made up of 18mm thick (min) PLB • Table includes wooden or modesty panel with side covered or uncovered • Minimum 3 drawer for storage with lock 		
 <p style="text-align: center;">All dimensions are in mm</p>		
(2) Name of the item	:	Chairs (72 Nos)
<p>Specification:</p> <ul style="list-style-type: none"> • Dimension W x D x H (minimum): 540 x 540 x 800 mm • Seat Height (minimum) : 450 mm • Seat size W x D (minimum) : 460 x 460 mm • Arm rest size L x W(minimum) : 200 x 60 mm – as shown in Fig (or) any suitable design. • Seat / Back assembly: Should be made of 10 mm thick hot pressed plywood with suitable injection moulded polymer which is upholstered with fabric and moulded polyurethane foam. • Foam: Polypropylene with density not less than 40 kg/m³ • Frame: Black powder coated mild steel tube of diameter not less than 25mm and 14BG thickness. • Type: Non-revolving. 		

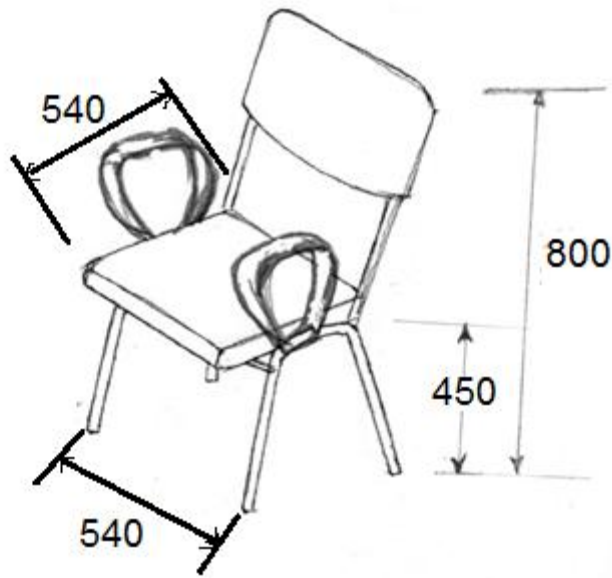

All dimensions are in mm

Quantity	:	Wooden working table with storage: (36 Nos), Chairs: (72 Nos).
Any other details/requirement	:	NIL
Warranty period required	:	One year
Delivery schedule expected after release of purchase order (in weeks)	:	8 Weeks
EMD (in Rupees)	:	Rs. 8,500/-
Performance security to be given by successful bidder after release of purchase order (in Rupees)	:	5% of the total value of purchase order

SECTION : 4 – PRICE SCHEDULE

Tender No. & Date: NITT/F.No:004-005/PLAN/2016-17/PRO/1 Dt: 22.08.2016

Tender No. & Date

Bidder's Offer No. & Date:

S. No.	Description of item	Rate /Qty in Rs. (excluding taxes)	Qty	Total Rs. (3) x (4)	VAT/ CST	Total Value in Rs. (5) + (6)
(1)	(2)	(3)	(4)	(5)	(6)	(7)
1.	<p>Wooden working table with storage</p> <ul style="list-style-type: none"> • Overall size (W x D x H) (minimum): 1200 mm x 590 mm x 750 mm. • Coated mild steel tube of diameter not less than 25mm and 14BG thickness. • Table top made up of 18mm thick (min) PLB. • Table includes wooden or modesty panel with side covered or uncovered. • Minimum 3 drawer for storage with lock 		36			
2.	<p>Chairs</p> <ul style="list-style-type: none"> • Dimension W x D x H (minimum): 540 x 540 x 800 mm • Seat Height (minimum) : 450 mm • Seat size W x D (minimum) : 460 x 460 mm • Arm rest size L x W(minimum) : 200 x 60 mm – as shown in Fig (or) any suitable design. • Seat / Back assembly: Should be made of 10 mm thick hot pressed plywood with suitable injection moulded polymer which is upholstered with fabric and moulded polyurethane foam. • Foam: Polypropylene with density not less than 40 kg/m³ • Frame: Black powder coated mild steel tube of diameter not less than 25mm and 14BG thickness. • Type: Non-revolving. 		72			
	Total Cost of Items					
	Service Tax (If any)					
	Packing & Forwarding charges (extra, if any)					
	Total all inclusive price delivered at NITT					

Signature of the Bidder :

Name and Designation :

Business Address :

Place :

Date :

Seal of the Bidder's Firm

(Note: The price bid should be submitted only as per the above format. No row shall be left blank. Please indicate NA, in case the item is "Not Applicable". If this format is not used or any column is left blank, then the bid will be rejected.)

SECTION : 5 – CONTRACT FORM

To be provided by the bidder in their business letter head

[Name of the Supplier's Firm] hereby abide to deliver the furniture items by the delivery schedule mentioned in the Section 3 of the Tender document for supply of the items if the purchase order is awarded.

The item will be supplied conforming to the specifications stated in the tender document without any defect and deviations.

Warranty will be given for the period mentioned in the tender document and service will be rendered to the satisfaction of NIT, Trichy during this period.

Signature of the Bidder :

Name and Designation :

Business Address :

Place :

Date :

Seal of the Bidder's Firm